

SCR-100 REMOTE CONTROL USERGUIDE



Version 1.2 | SCR 100-UG-ES-V12

Manufacturer:



Naocontrol, S.L.

Félix Acevedo, 1, 6D2

15008 A Coruña

ESPAÑA

Web: www.naocontrol.com

Email: naocontrol@naocontrol.com



This device complies with the applicable requirements of the European Union's regulations concerning safety and electromagnetic compatibility.

© **2023 Naocontrol, S.L.**

All rights reserved

Table of Contents

1. Safety and environmental protection warnings.....	4
2. System overview	5
2.1 Typical installation schematic	6
2.2 Device description	7
• Status Indicator. Selected windlass indicator. Power button. Station selection button.....	7
• Bow thruster control lever. Starboard engine fast forward button. Starboard engine control lever. Starboard engine fast reverse button. Stern thruster control lever. Horn button.....	8
• Vibration warnings. Battery charge indicator. Lights on/off button. Port engine fast reverse button. Port engine control lever.....	9
• Port engine fast forward button. Windlass selection button. Windlass control buttons.....	10
3. Remote control operation.....	11
3.1 Power on/off.....	11
3.2 Checking the radio link.....	11
3.3 Engine control.....	11
3.3.1 Engine control activation.....	11
3.3.2 Engine control signaling.....	12
3.3.3 Engine control priorities.....	12
3.4 Thrusters control.....	12
3.5 Windlasses control.....	12
3.6 Horn and light control.....	13
3.7 Battery charging.....	13
4. Technical information.....	14
5. Problems diagnosis and solutions.....	15
6. Maintenance instructions.....	15
7. Warranty information.....	16
8. NOTES.....	17

1. Safety and environmental protection warnings





☞ *Read carefully and follow the warnings and instructions in this manual and the documentation that accompanies the product.*

Shipcontroller installation

 *The Shipcontroller system must be installed and adjusted by qualified authorized technicians, and following the installation instructions provided with each system.*

Using Shipcontroller

 *Shipcontroller has been designed to help with low-speed maneuvers, particularly in anchoring or docking scenarios. Although it has been developed and manufactured to be highly safe and reliable, you should always follow good maritime safety and navigation practices, in particular:*

 *Make sure to follow suitable procedures and to have the adequate crew and resources to maintain control of the vessel at all times and minimize the risk of damaging persons or things.*

 *Turn the system off when not in use.*

ENVIRONMENTAL WARNINGS

Restriction of Hazardous Substances (RoHS)

RoHS

This system has been designed in accordance with RoHS regulations which restrict the use of substances harmful to the environment, such as lead, mercury or cadmium.

Use of disposable or rechargeable batteries:



The remote control unit has been designed to use rechargeable batteries. Batteries must be disposed of according to current regulations, by placing them in a suitable container.

Product Disposal:



When you decide to discard this product, for example, at the end of its life cycle, do it according to the ordinances or regulations governing the disposal of electronics devices.

2. System overview

The SCR100 remote control unit is part of the Shipcontroller modular system. It can be used with most bow and stern thruster and engine configurations.

Main features:

- Bidirectional wireless data link with 128-bit encryption
- Two-step engine control: two rpm levels forward and reverse.
 - The two-step thrust feature availability depends on the type of engines and electronic controls of the boat.
- Bow and stern thruster ON/OFF control.
 - Can be used with proportional thrusters by using an optional interface.
- Control of up to two anchor windlasses.
 - The remote has a button to select main or secondary windlass.
- Auxiliary control channels for siren and deck lights.
- Internal rechargeable lithium polymer battery with wireless charging.
 - Wireless charger according to Qi standard.
- IP65-rated, resistant to ingress of water and dust.
- IP67-rated high quality internal pushbuttons, with a long service life.

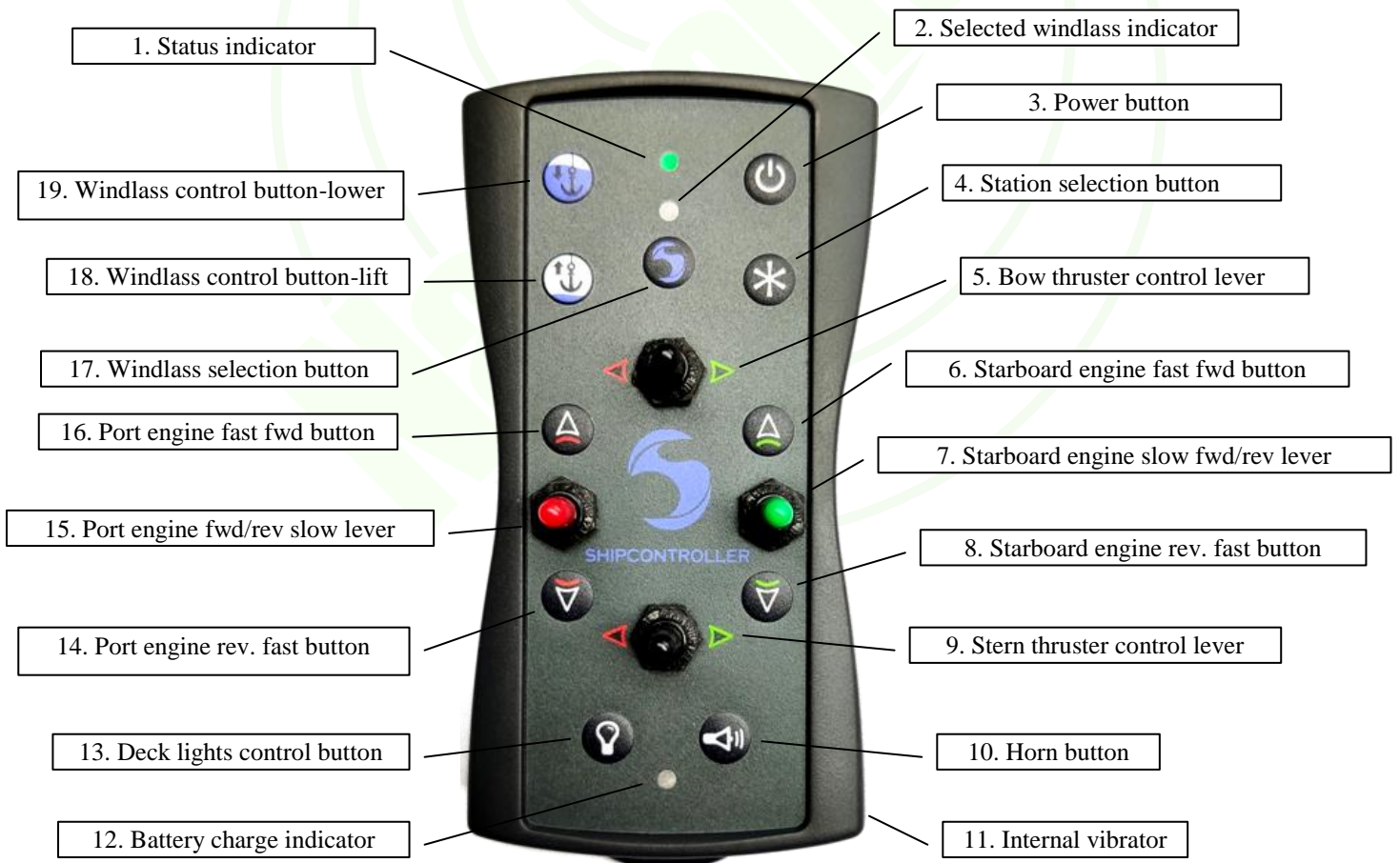





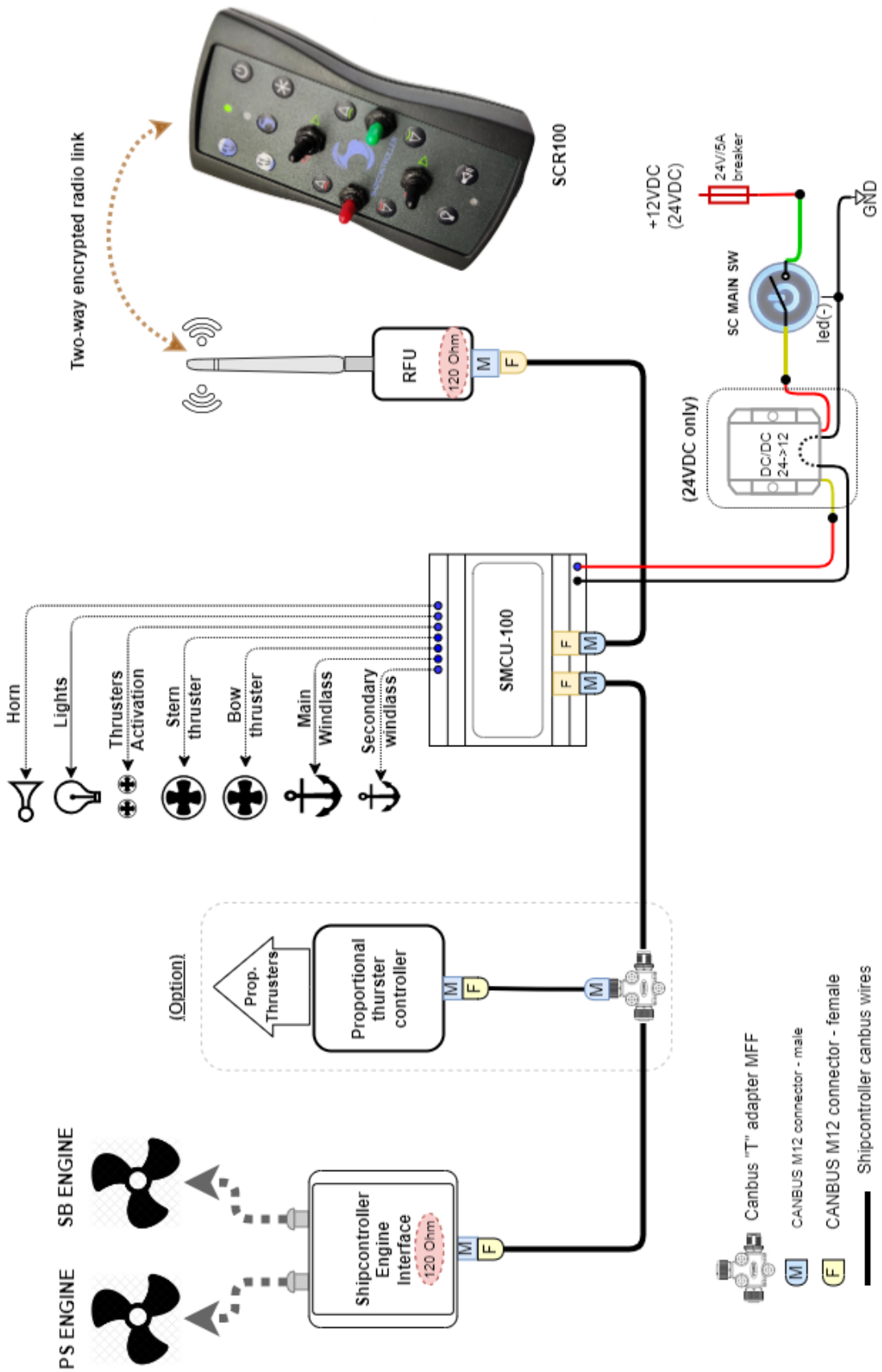

2.1 Typical installation schematic

SHIPCONTROLLER SC100 SYSTEM - GENERIC ENGINE INTERFACE



2.2 Device description

2.2.1 Status indicator

LED	Meaning
	Red light permanently on: * Radio link not established: no radio coverage, or the Shipcontroller base system is turned off or unavailable
 Blink 1/sec.	Red light blinking once per second: * Battery low.
 Blink 1/sec.	Green light blinking once per second: * Radio link established. * No engine control. All other functions available.
	Green light permanently on: * Radio link established. * Engine control available. All functions available.
 Blink 5/sec.	Green light blinking 5 times/second: * Commands being transmitted. (A push button or control lever of the remote control has been activated).
	Green and red lights blinking at the same time (5 times/second): * Diagnostics failure.

2.2.2 Selected windlass indicator

This led indicates which of the anchor windlasses is selected:

- Led off: Main windlass selected
- Led flashing twice: secondary windlass selected

To change the windlass selection, press the windlass selection button [17].

2.2.3 Power button

Push to turn the remote on/off.



Auto power-off function: The SCR100 remote will automatically turn off 30 seconds after the base system has been turned off, if no buttons or levers are activated during that period of time.

2.2.4 Station selection button

Some electronic engine control configurations allow the activation of the remote control station by pressing this button. See section 3.3 for more information.

2.2.5 Bow thruster control lever

Move the lever towards the green arrow next to it to activate the bow thruster to starboard side, or move it towards the red arrow to activate the bow thruster to port side. The lever returns to neutral (central position) when released.

2.2.6 Starboard fast forward button

If your system allows proportional control of the engines, this button will activate the starboard engine fast forward motion. The “fast” term is relative; it does not entail high rpm values or fast speed.

If the proportional control option is not available, then this button is used to perform the starboard engine slow forward maneuver.

2.2.7 Starboard engine control lever

Pushing this lever towards the front of the remote control will activate the slow forward motion of the starboard engine. Pushing it towards the rear of the remote will activate the slow reverse motion of the starboard engine. The lever returns to neutral (central position) when released.

2.2.8 Starboard engine fast reverse button

If your system allows proportional control of the engines, this button will activate the starboard engine fast reverse motion. The “fast” term is relative; it does not entail high rpm values or fast speed.

If the proportional control option is not available, then this button is used to perform the starboard engine slow reverse maneuver.

2.2.9 Stern thruster control lever

Move the lever towards the green arrow next to it to activate the stern thruster to starboard side, or move it towards the red arrow to activate the stern thruster to port side. The lever returns to neutral (central position) when released.

2.2.10 Horn button

Press this button to activate the yacht’s siren.

2.2.11 Vibration warnings

The remote control unit has an internal vibration motor for additional notification of some events such as:

Vibration signal	Meaning
One short pulse	* Start test completed. * Engine control recovered.
Continuous, while holding down any button or engine control lever	* Radio link not established or lost. * Remote unit not accepted/supported in the network (for NET systems with several remotes). * Engine control not available.
Continuous, as long as any side propeller or windlass control lever is activated	* Radio link not established or lost.
Two long pulses	* Engine control lost.

2.2.12 Battery charge indicator

This led indicator will light up when the remote control unit is placed over a powered Qi wireless charger. The possible states of this indicator are as follows:

- Off: charging adapter disconnected or turned off.
- Red: battery charging.
- Green or blue: charging completed.

Disconnect the charger from the power supply when charging is complete.

2.2.13 Lights on/off button

If the light control output has been enabled, the state of the output will change from on to off and vice versa each time this button is pressed briefly.

2.2.14 Port engine fast reverse button

If your system allows proportional control of the engines, this button will activate the port engine fast reverse motion. The “fast” term is relative; it does not entail high rpm values or fast speed.

If the proportional control option is not available, then this button is used to perform the port engine slow reverse maneuver.

2.2.15 Port engine control lever

Pushing this lever towards the front of the remote control will activate the slow forward motion of the port engine. Pushing it towards the rear of the remote will activate the slow reverse motion of the port engine. The lever returns to neutral (central position) when released.

2.2.16 Port engine fast forward button

If your system allows proportional control of the engines, this button will activate the port engine fast forward motion. The “fast” term is relative; it does not entail high rpm values or fast speed.

If the proportional control option is not available, then this button is used to perform the port engine slow forward maneuver.

2.2.17 Windlass selection button

Use this button to select main/secondary windlass. Read section 3.5 for more details.

2.2.18 Anchor windlass control buttons

- The "down arrow" button allows the anchor to be lowered.
- The "up arrow" button allows the anchor to be raised.

Read section 3.5 for more details.

3. Remote control operation

The remote control unit features arrows and other symbols near the control buttons and levers to help you identify their effect on boat maneuvering. Many users choose to orient the remote control unit so that it always matches the orientation of the boat to avoid maneuvering errors.

3.1 Power on/off

To turn on the unit, press the on/off button. To turn off the remote control unit, press the on/off button. The vibrator will indicate shutoff by means of two short pulses.

Auto power off function:

The remote control will automatically turn itself off 30 seconds after losing the data link (red led on) if no lever or button has been operated during that time. That is, if we turn off the Shipcontroller system on the boat, the remote unit will turn itself off after 30 seconds (if not in use).

3.2 Checking the radio link

The remote control constantly monitors and verifies the quality and reliability of the wireless link, indicating the link status to the user by means of optical signaling (LEDs) and vibration.



The loss or interruption of the radio link (due to shutdown of the remote or the base, loss of coverage, breakdown, or other cause) will imply that:

- None of the remote control or telemetry functions will be available.
- All controlled systems will immediately return to their idle (neutral/stop) position.
- Immediately notify or go to the boat's steering position to regain control of the boat.

3.3 Engine control

3.3.1 Engine control activation

The procedure for acquiring control of the engines from the remote control depends on the particular configuration of electronic controls available on your boat, and the corresponding configuration of the Shipcontroller system.

The SCR100 remote control unit allows you to:

- Transmit from the remote a request for activation of the engine control by pressing the "*" button on the remote. (Station selection button).
- Signal the status of the engine control (green light blinking, or permanently on).

Please refer to the engine interface manual provided together with your system for information on the engine control activation procedure.

3.3.2 Engine control signaling

If your system configuration supports engine control status signaling, it will be signaled as follows:

- * Green LED blinking (1/second): engine control not available.
- * Green light permanently on: engine control available.

If your boat's electronic engine controls system does not support engine control status signaling, the status LED will be on as long as there is an established radio link.

3.3.3 Engine control priorities

In case the engine control levers and/or engine control buttons are operated simultaneously, the following priority rules apply:

The controls for each engine (port and starboard) are independent and can be activated simultaneously without restriction.

Forward has priority over reverse. For example, if the fast forward and fast reverse buttons for the starboard engine are activated at the same time, the fast forward maneuver will be executed.

The "fast" buttons will take precedence over the "slow" control levers.

3.4 Thrusters control

Push the bow or stern side thruster control levers sideways towards the green (starboard) or red (port) marks next to the levers to activate the thrusters in the corresponding direction. These levers can be used simultaneously without limitation.

In general, you will be able to use the boat's thruster controls while your Shipcontroller is on, just do not use the Shipcontroller remote unit's thruster controls at the same time as the boat's thruster controls.

3.5 Windlasses control

The SCR100 remote control is capable of controlling two windlasses. In order to operate the windlasses:

- 1) Check which windlass is selected by looking at the selected windlass indicator [2]. If the indicator is off, it means the main windlass is selected. If the indicator flashes, it means the secondary windlass is on.
- 2) If necessary, change the windlass selection using the windlass selection button [17].
- 3) Use the [18] or [19] buttons to raise or lower the selected anchor.

Active windlass memory feature:

The SCR100 remote will memorize the selected windlass when you turn the unit off.

3.6 Horn and Lights control

The SCR100 remote has two auxiliary control channels intended to operate the horn and the deck lights or a spotlight, but they can be used for other purposes.

“Light” button:

This button is configured to function as a toggle switch. Each time the button is pressed and released, the state of the output will change from on to off, or the other way round.

“Horn” button:

This button is configured as a pushbutton. The control output will be active as long as you press and hold this button, and inactive when the button is released.

3.7 Battery charging

The remote control unit includes an internal rechargeable lithium-ion battery. To charge the battery, you must use a wireless charger compatible with the Qi standard.

(A suitable Qi wireless charger is offered as an option).

In order to charge the battery:

1. Turn the remote control unit off.
2. Turn on the Qi charger and place the remote unit on top, adjusting the position of the remote unit until the battery charging led lights up.
3. Wait until the charge indicator LED changes its color to green or blue.
4. Disconnect the charger.



Always disconnect the charger when charging is complete.

4 Technical information

4.1 General

Dimensions: 125mm x 65mm x 27mm
Weight: 135gr.
Operating temperature: 0°C ~45°C
IP degree of protection: IP65

4.2 Electrical

Power supply: 3.7V/350mAh LiPo rechargeable battery, with protection circuit.
Battery charging: Internal Qi standard receiver

4.3 Radio system

Type: Bidirectional data link
Radio band: ISM 2.4GHz
Maximum transmission power: 10mW ERP
Modulation: DSSS + Offset QPSK
Estimated coverage: < 500m outdoors (LOS)
< 80m indoors
Access protocol: IEEE 802.15.4
Addressing: 64-bit
Data encryption: AES, 128 bits.
Approvals: CE (ETSI), FCC, C-TICK, IC, Telec.

5. Problem diagnosis and solutions

Symptom	Meaning. Suggested actions.
When you turn the remote control unit on, the green and red LEDs blink several times and then the remote control turns off.	<ul style="list-style-type: none"> • The start-up diagnosis system has detected a fault. • The radio module is self-configuring. • Battery discharged. • <i>Turn off and on, try again. If the problem is not solved, contact technical service.</i>
The remote does not turn on.	<ul style="list-style-type: none"> • Battery fully discharged. • Faulty remote control unit. • <i>Recharge the battery. If this does not solve the problem, contact technical service.</i>
The remote turns on, but the status LED is always red, and the remote control unit vibrates when I try to use any button or lever.	<ul style="list-style-type: none"> • The Shipcontroller base system is turned off. Turn it on. • You are not within the radio coverage area. • <i>There is a fault in the radio system. Contact technical support.</i>

6. Maintenance instructions

CLEANING:

Use a damp, soft cloth. Do not use detergents or solvents.

RECHARGEABLE BATTERY:

All rechargeable batteries undergo an aging process that decreases their charge capacity. If you notice that the battery usage time is decreasing, ask for a replacement battery.

EVERY TWO YEARS:

- Thoroughly inspect the wiring and connections of the Shipcontroller system.
- Request a technical check that involves opening the remote control unit and the different modules of the Shipcontroller system to verify the tightness and good condition of all connections, components and circuit boards.
- Check the calibration of the engine control interface (in case of analog control systems).
- Check the tightness and integrity of the remote control unit.

7. Warranty information

SHIPCONTROLLER WARRANTY

All Shipcontroller systems are warranted to be free from manufacturing defects in terms of materials and/or workmanship for three years from the date of original purchase. The warranty covers only the repair or replacement of defective equipment or parts.

The Shipcontroller guarantee will be void if any part of the system shows signs of having been tampered with or disassembled, beyond the operations necessary for installation and maintenance.

Installation, calibration and removal of the system must be performed by an authorized technician. Otherwise, the warranty may be void.

All costs of transporting the product to and from the Shipcontroller service center will be borne by the customer.

THIS WARRANTY DOES NOT COVER:

- Any damage, failure or loss caused by abuse, neglect, improper repair, improper maintenance or installation, alteration, modification, failure to follow the instructions or warnings in the user's manual, failure to follow maintenance instructions, use outside the operating ranges, excessive or improper operation or other abnormal use.
- Any damage, failure or loss caused by accidents, natural disasters or by reason of force majeure, or caused by water due to improper use.

Contact information:

naocontrol@naocontrol.com
Naocontrol, S.L.
Félix Acevedo, 1, 6º D2
15008 A Coruña
SPAIN





www.SHIPCONTROLLER.com



www.NAOCONTROL.com